

FRONT VIEW  
1:55

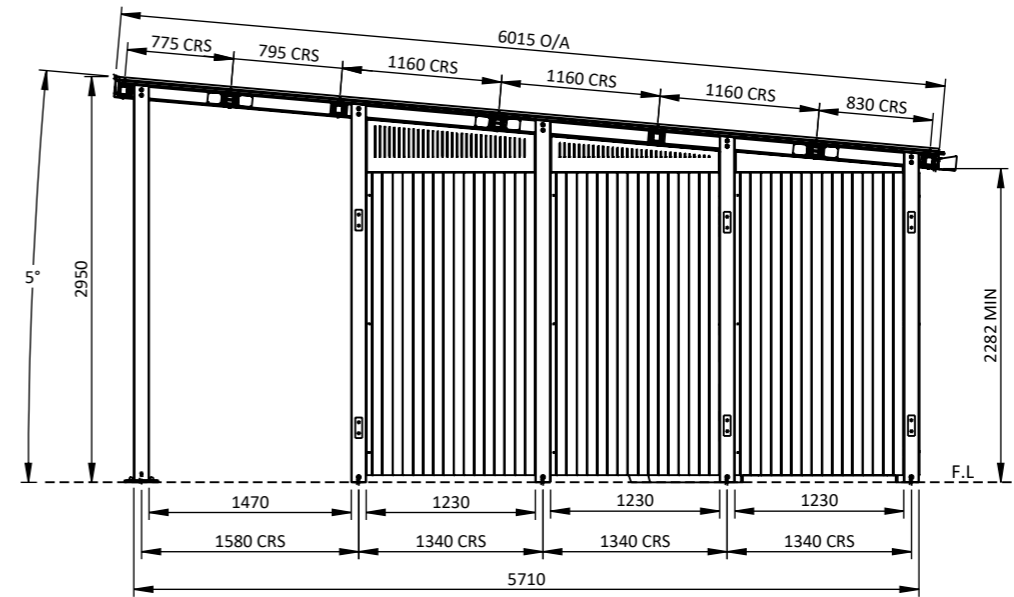

SIDE VIEW  
1:55

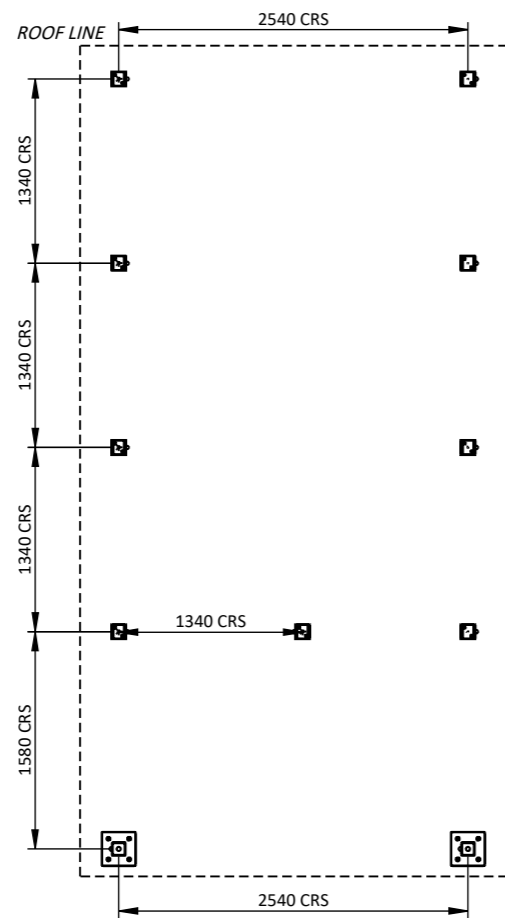

FOUNDATION PLAN  
1:55

CUSTOM BLUE ORB 0.6 BMT ROOF SHEET



DIMETRIC VIEW  
1:55

**GOSSI**  
PARK & STREET FURNITURE

1082 Kingsford Smith Drive  
EAGLE FARM - QLD 4009  
Phone: (07) 3877 2856  
Fax: (07) 3877 2890  
www.gossi.com.au Email:  
sales@gossi.com.au

©Copyright - This drawing  
is the property of G.James  
Glass & Aluminium Pty Ltd  
it must not be copied or  
shown to third parties  
without written consent

PROJECT	<b>AMT-100S</b>	
TITLE	GENERAL ARRANGEMENT	
DATE	30/01/2025	SCALE
		1:55
DRAWING NUMBER	AMT-100S-SLS-ISSUE-B-1	

**GENERAL MATERIALS:**

- Posts, framing and roofing components in extruded aluminium.
- Roof sheeting in corrugated profile coated steel.

**FINISHES**

- Posts, framing and brackets in Class AA25 Anodising finishes, Polyester Powder Coating or wood look aluminium.  
*Note: Colour may vary between alloys.*
- Spigots in Polyester Powder Coating finishes.  
*Note: 60 Micron minimum on visible faces.*

**HARDWARE**

- Stainless steel anti-vandal fixings.
- Roof screws colour matched roof sheets.

BUILDING COMPLIES WITH AS 1428.1 - 2021 DISABILITY ACCESS STANDARDS

UNISEX PWD WATER CLOSET COMPLIES WITH AS 1428.1 - 2021 STANDARDS

UNISEX AMB WATER CLOSET COMPLIES WITH AS 1428.1 - 2021 STANDARDS

**LEGEND:**

- WD = Disability compliant toilet pan
- WA = Ambulant compliant toilet pan
- WDC = Disability compliant toilet pan (with cistern)
- RC = In-wall remote cistern
- BD = Disability compliant handwashing basin
- B = External Basin
- LDR = LH disability compliant hand rail
- RDR = RH disability compliant hand rail
- AR = Ambulant compliant hand rail
- CT = Changing table
- SH = Shelf
- ALH = Anti Legature coat Hanger
- EB = Electrical Box
- FPSS = Front Privacy Screen Spigot

UNISEX PWD = Unisex disability compliant water closet

UNISEX AMB = Unisex ambulant compliant water closet

EXCLUSION ZONES = - - - - -

CIRCULATION SPACES = - - - - -

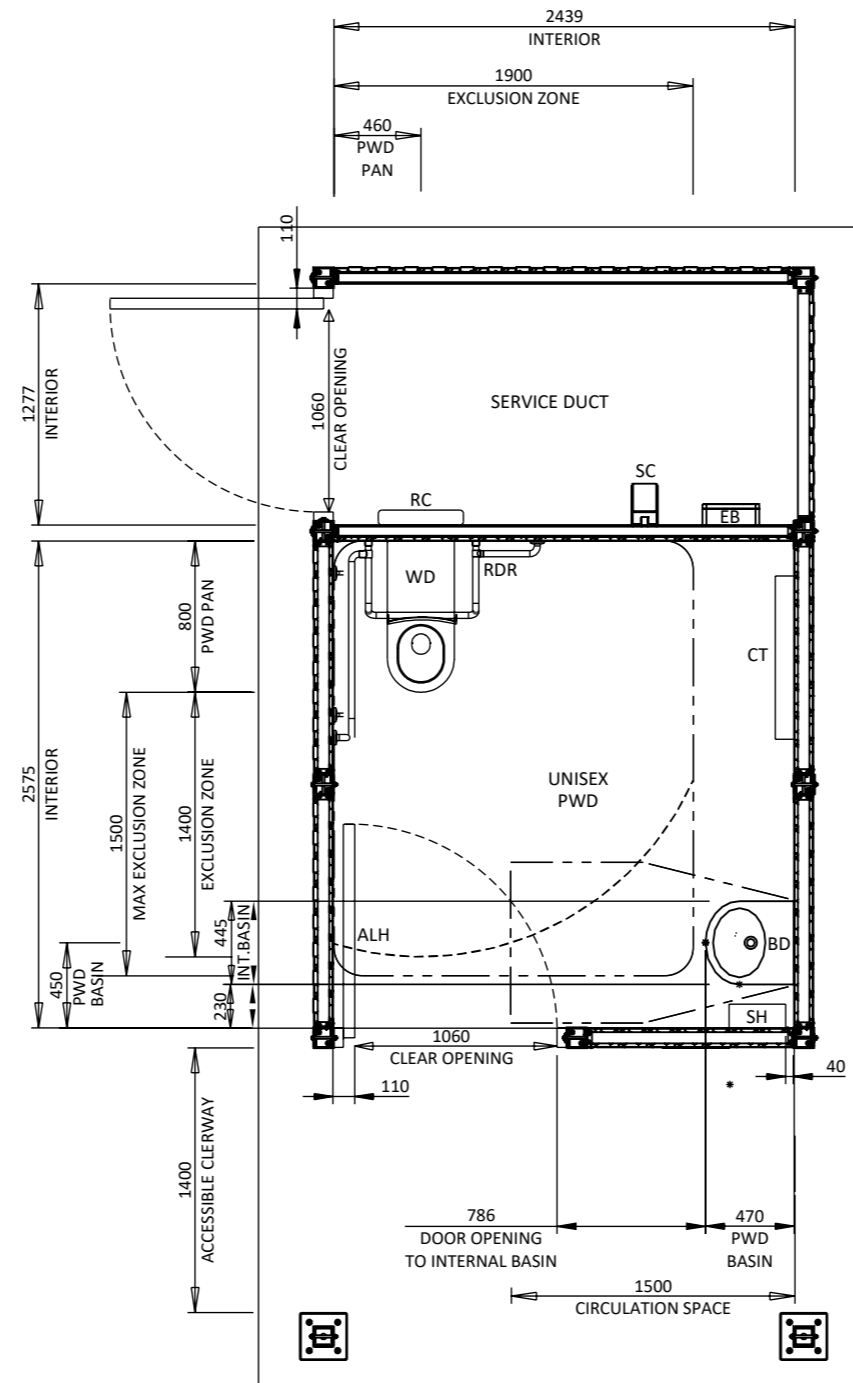

FLOOR PLAN 1:40



1082 Kingsford Smith Drive  
EAGLE FARM - QLD 4009  
Phone: (07) 3877 2856  
Fax: (07) 3877 2890  
www.gossi.com.au Email:  
sales@gossi.com.au

©Copyright - This drawing is the property of G. James Glass & Aluminium Pty Ltd it must not be copied or shown to third parties without written consent

PROJECT	AMT-100S		
TITLE	FLOOR PLAN		
DATE	30/01/2025	SCALE	1:40
DRAWING NUMBER	AMT-100S-SLS-ISSUE-B-2		
			A3

**GENERAL MATERIALS:**

- Posts, framing and roofing components in extruded aluminium.
- Roof sheeting in corrugated profile coated steel.

**FINISHES**

- Posts, framing and brackets in Class AA25 Anodising finishes, Polyester Powder Coating or wood look aluminium.  
*Note: Colour may vary between alloys.*
- Spigots in Polyester Powder Coating finishes.  
*Note: 60 Micron minimum on visible faces.*

**HARDWARE**

- Stainless steel anti-vandal fixings.
- Roof screws colour matched roof sheets.

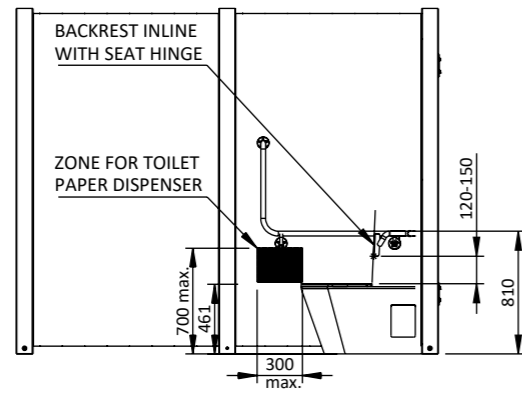

○ PWD LHS WALL

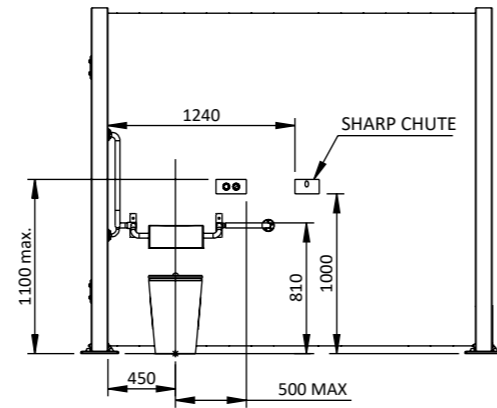

○ PWD REAR WALL

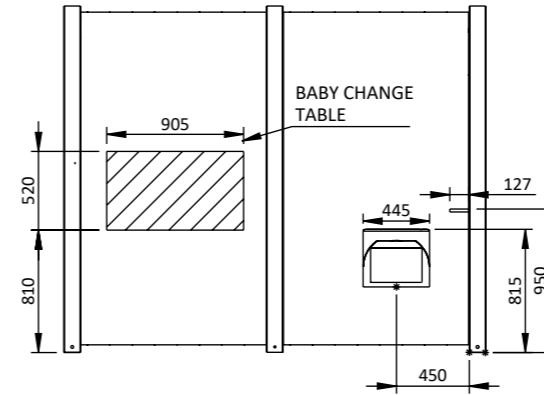

○ PWD RHS WALL

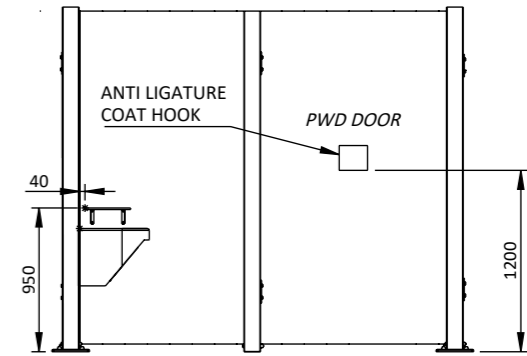

○ PWD INTERNAL FRONT WALL

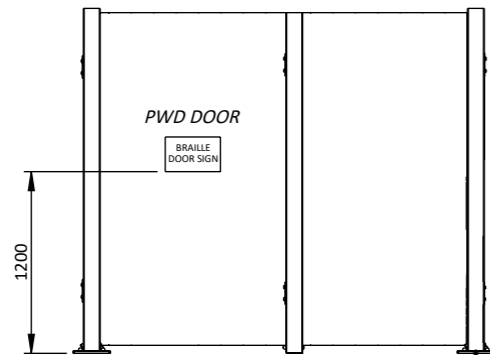

○ PWD EXTERNAL FRONT WALL

**GENERAL MATERIALS:**

- Posts, framing and roofing components in extruded aluminium.
- Roof sheeting in corrugated profile coated steel.

**FINISHES**

- Posts, framing and brackets in Class AA25 Anodising finishes, Polyester Powder Coating or wood look aluminium.  
*Note: Colour may vary between alloys.*
- Spigots in Polyester Powder Coating finishes.  
*Note: 60 Micron minimum on visible faces.*

**HARDWARE**

- Stainless steel anti-vandal fixings.
- Roof screws colour matched roof sheets.